



### 概述 General

1. BTFA系列全自动分体式燃烧器的输出功率高达42MW, 在对应的燃烧功率、锅炉背压和不同燃料的情况下可选配适当的鼓风机型号。所配置的程序控制器和火焰探测器都带24小时火焰信号自检功能。
2. 全自动的燃油燃烧器特别为高调节比而设计, 因此这些BTFA系列燃烧器的控制范围很广泛。
3. 燃油雾化方式: 可选择采用高压机械雾化或采用低压介质雾化。
4. 主管路安置在燃烧器本体上, 独立的油泵组, 包括油泵和油过滤器。
5. 根据锅炉的炉膛尺寸火焰长度和直径可以通过调整二次风的旋风挡板角度来设定, 该功能是专门为不同锅炉厂家的炉膛设计而制作的。
6. 多种控制方式, 标准配置为机械比例, 但可为不同操作上的需求而设, 如电子比例带氧量控制器, 电子比例控制双燃料燃烧等系统。

1. The power range of BTFA series full-automatic separated type burner is 42MW, it can be equipped with the suitable fan according to the combustion power, boiler back pressure and different fuel. Both the program controller and flame detector have 24-hour self detection of flame signal.
2. The full-automatic fuel oil burners are specially designed for the supremely accurate adjusting ratio, therefore, BTFA series burner has wide range in the power output control.
3. Fuel atomization type: optional high pressure mechanical atomization or low pressure medium atomization.
4. The main oil pipeline is mounted at the burner body, individual oil pump unit, including the oil pump and oil filter.
5. According to the boiler hearth size, the flame length and diameter may be set by adjusting the angle of secondary air cyclone plate. This function is specially provided for the different manufacturers boiler hearths.
6. There are kinds of control modes, the standard configuration is the mechanical scale, however, it can be set according to the different operation demands, for instance, the electronic-scale oxygen controller, electronic-scale control dual-fuel combustion system, etc...

### 技术参数 Technology Data

功率 Power kW	型号 Model	订货编号 Order No.	电源 Power supply	最大粘度 Max Viscidity E@20°C	燃油量(轻油) Fuel (Light oil) kg/h	包装尺寸 Packing size cm	重量 Net weight kg
954 ~ 6042	BTFA6L	202 29 150	380V 50Hz	1.5	80 ~ 510	1553x1358x1279	
1100 ~ 8230	BTFA8L	202 29 151	380V 50Hz	1.5	93 ~ 694	1553x1358x1279	
1400 ~ 11160	BTFA10L	202 29 152	380V 50Hz	1.5	118 ~ 940	1840x1400x1520	
2232 ~ 14511	BTFA15L	202 29 153	380V 50Hz	1.5	188 ~ 1224	1930x1340x1630	
3590 ~ 22500	BTFA25L	202 29 154	380V 50Hz	1.5	303 ~ 1897	2180x1580x1890	
5500 ~ 34500	BTFA35L	202 29 155	380V 50Hz	1.5	464 ~ 2908	2530x1710x1970	
7000 ~ 42000	BTFA45L	202 29 156	380V 50Hz	1.5	590 ~ 3541	2980x2040x2340	

### 外形尺寸图 Outline size diagram

型号Model: BTFA6L...45L

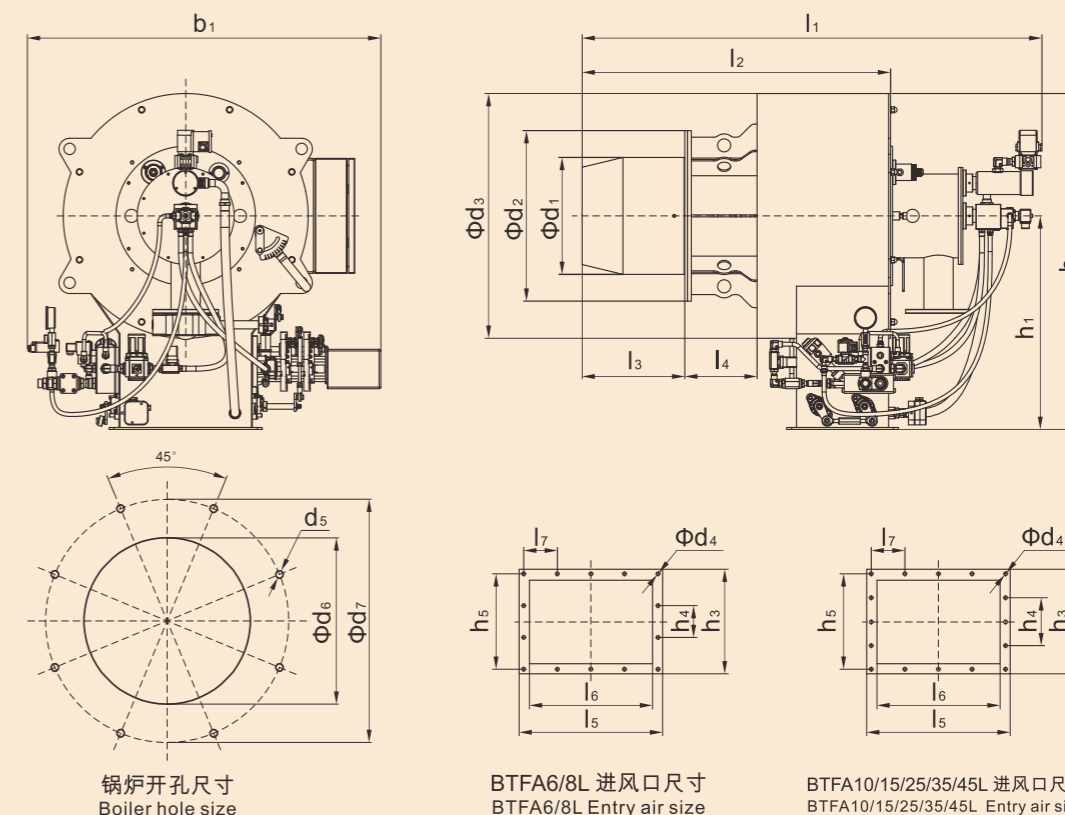

单位Unit: mm

型号Model	b <sub>1</sub>	l <sub>1</sub>	l <sub>2</sub>	l <sub>3</sub>	l <sub>4</sub>	l <sub>5</sub>	l <sub>6</sub>	l <sub>7</sub>	Φd <sub>1</sub>	Φd <sub>2</sub>
BTFA6L	1074	1399	938	312	220	466	400	4-109	356	519
BTFA8L	1208	1428	968	342	220	601	535	5-114.2	400	564
BTFA10L	1223	1664	1154	375	258	636	550	5-121.2	447	655
BTFA15L	1153	1754	1194	383	252	688	600	5-131.6	497	705
BTFA25L	1399	2000	1433	479	325	858	750	5-163.6	616	820
BTFA35L	1531	2357	1741	603	330	958	850	6-153	703	920
BTFA45L	1856	2802	2082	811	312	1110	980	6-176.7	870	1130

单位Unit: mm

型号Model	Φd <sub>3</sub>	Φd <sub>4</sub>	d <sub>5</sub>	Φd <sub>6</sub>	Φd <sub>7</sub>	h <sub>1</sub>	h <sub>2</sub>	h <sub>3</sub>	h <sub>4</sub>	h <sub>5</sub>
BTFA6L	1074	14-Φ9	8-M12	366	455.2	650	1022.5	340	103.3	271
BTFA8L	1208	16-Φ9	8-M12	410	500.2	650	1022.5	340	103.3	271
BTFA10L	1223	18-Φ11	8-M14	460	580.2	770	1245	490	230	401
BTFA15L	1153	18-Φ11	8-M12	510	630	820	1317	500	240	411
BTFA25L	1399	18-Φ12	8-M14	626	750.2	960	1600	590	275	480
BTFA35L	1531	20-Φ12	8-M16	715	850	1000	1690	722	136.4	612
BTFA45L	1856	22-Φ14	8-M20	880	1050.2	1200	2050	876	165.2	745